

MULTI THREE COMPACT

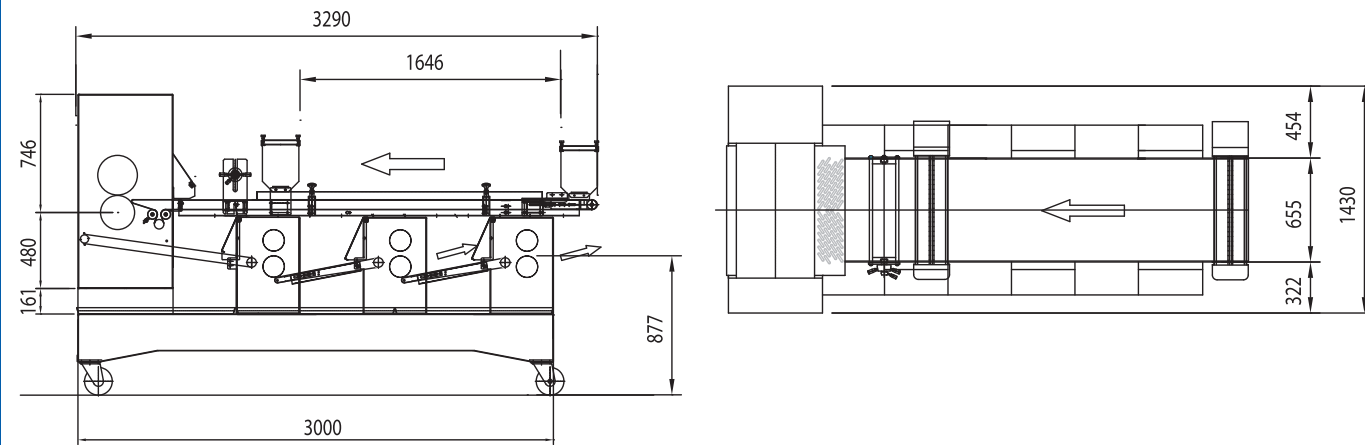

Q&B GRAFICHE s.r.l 0912

believe in!



ALBA BAKERY AND PASTRY EQUIPMENT

LINEE DI LAMINAZIONE

LAMINATING LINES

TWIN MULTIROLLER

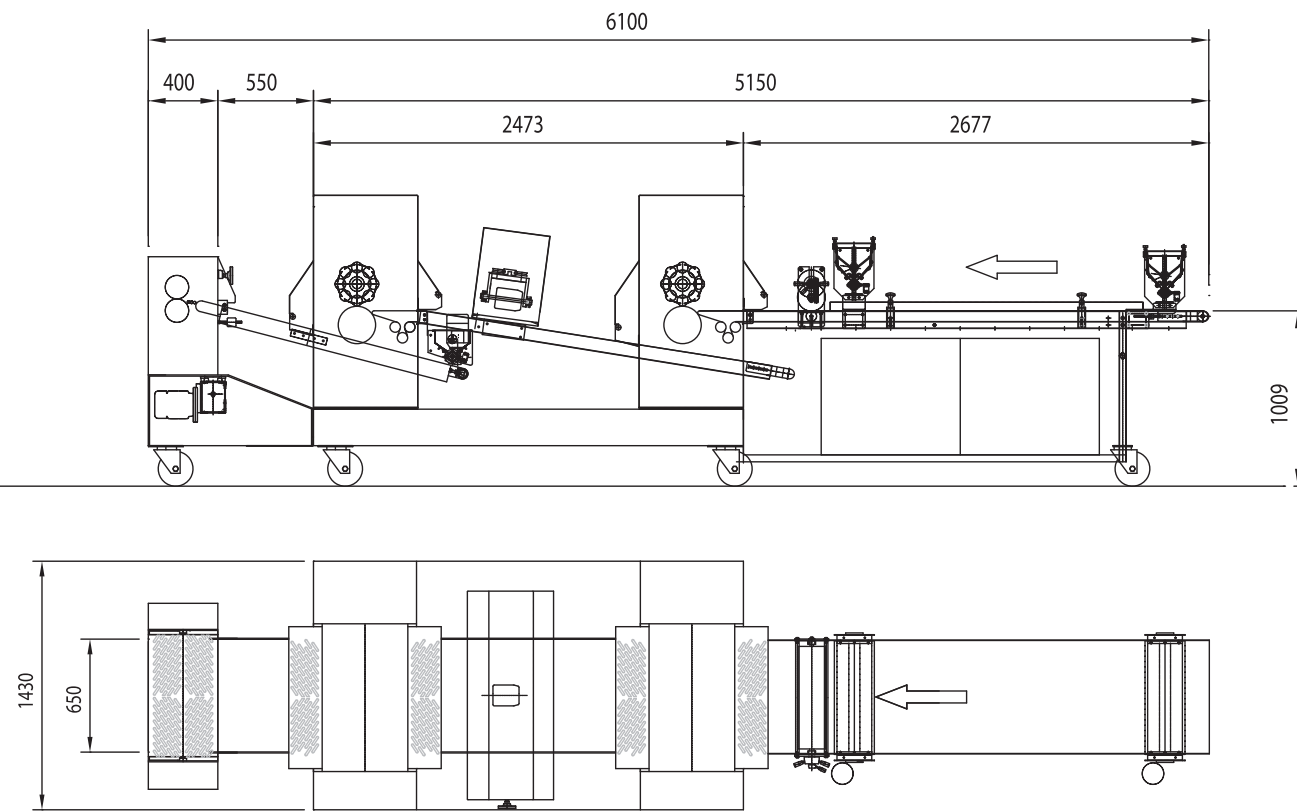

(Tutti i dati tecnici qui riportati possono essere variati dal costruttore mantenendo inalterata la funzionalità dell'impianto)

(All the above mentioned technical data can be modified accordingly without changing the functionality of the unit)



ALBA BAKERY AND PASTRY EQUIPMENT

ALBA & Telkosservice s.r.l.

Via delle Industrie, 16/B 35010 VILLAFRANCA PAD. (PD) - ITALY

Tel. +39 049.9070380 - Fax +39 049.9074042

www.albaequipment.it - e-mail: sales@albaequipment.it

Rivenditore



MULTI-THREE COMPACT





 Nel medesimo spazio di una sfogliatrice tradizionale, abbiamo realizzato una laminazione in continuo con un'altissima resa in qualità e produttività

 In the same space of a traditional sheeter, we realize a continuous lamination with a very high quality and productivity

TWIN MULTIROLLER



 Il modo innovativo ed economico di laminare vari tipi di pasta in un foglio continuo allo spessore desiderato. Questa linea è concepita in particolare per l'alimentazione automatica delle macchine per croissant o dei tavoli di lavoro.

 The latest and most economical way to sheet many types of dough into a continuous sheet to the desired thickness. It has been specially designed for the automatic feeding of croissant lines or make up tables.

LINEA PREPARAZIONE PASTELLI DOUGH BILLETS PREPARING LINE

 In uno spazio incredibilmente ridotto siamo riusciti a prepararvi una linea pastelli che rispetta qualità e produttività

 In a very small space we can give you a dough billets line which respects quality and productivity

